

The ELECTROMAGNETIC FIELD

In the year 2003, it is still the case that the most important single scientific development for our world has been the understanding of the EM field. Although many played a role in achieving this, the 2 most important advances were made by Faraday, working his whole life in the Royal Institution, and Maxwell, working in Scotland and Cambridge, England.

In a long series of experiments Michael Faraday was led to his idea of electric and magnetic field lines- which he viewed as force fields which could move and had their own dynamical properties (such as a “string tension”).

His understanding led him to many useful inventions, including the dynamo.

Maxwell made fundamental contributions to many parts of what we now call theoretical physics- a subject he did much to create. He gave the first theory of the EM field, an entity which he invented to explain the existing results. This field combined the electric and magnetic fields, and their charge sources, into one.



J.C. Maxwell (1831-1879)

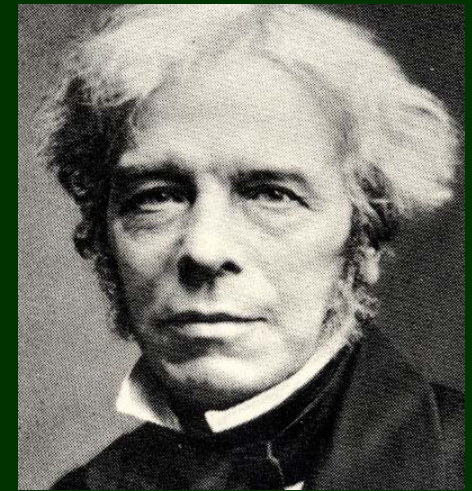

M. Faraday (1791-1867)

ELECTROSTATIC FIELDS I

We begin with simple electric field coming from static charges. The field from a single electric charge q_1 has a strength that looks just like the gravitational field from a mass- it has a strength which goes like (here k is a constant):

$$E = k \frac{q_1}{r^2}$$

and the force on a second charge q_2 is $F = Eq_2$, so that we can write

$$F = k \frac{q_1 q_2}{r^2}$$

Just as with the gravitational interaction, we can say that this force comes from an electrostatic potential

$$V(r) = -k \frac{q_1}{r}$$

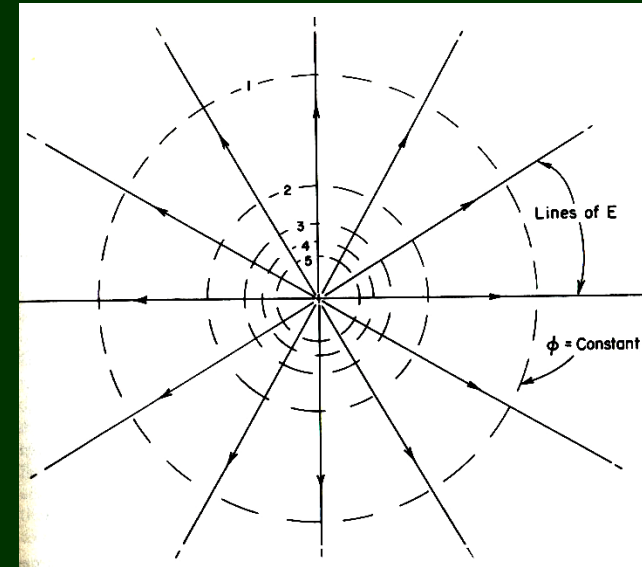

Field lines from +ve charge

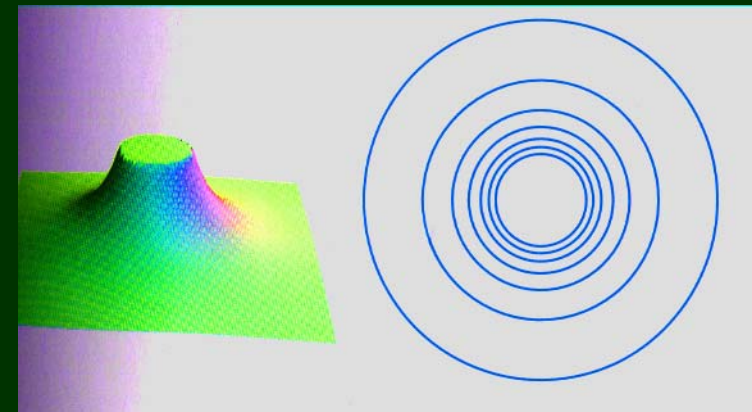

Electrostatic potential from +ve charge

However there is a crucial difference between electrostatic and gravitational forces- the charges q_1 , q_2 , etc., can be positive or negative (whereas masses can only be positive). Thus electrostatic forces can be attractive or repulsive.

ELECTROSTATIC FIELDS II

A very interesting field configuration is the “dipolar” field, produced by a pair of oppositely charged particles. Of course these 2 charges attract each other- however, what we learn from the pictures below is how the electric field extends away from the dipole, measured by what forces act on some test positive charge. This positive charge is repelled by the positive charge in the dipole (which acts as a potential “hill”), and attracted by the negative charge (which shows a potential well).

The interesting thing is that no matter how far away we get from a dipole, the field from the +ve and -ve charges never exactly cancel (actually the field decreases proportionally to $1/r^3$, instead of the $1/r^2$ dependence that one gets for a single isolated charge).

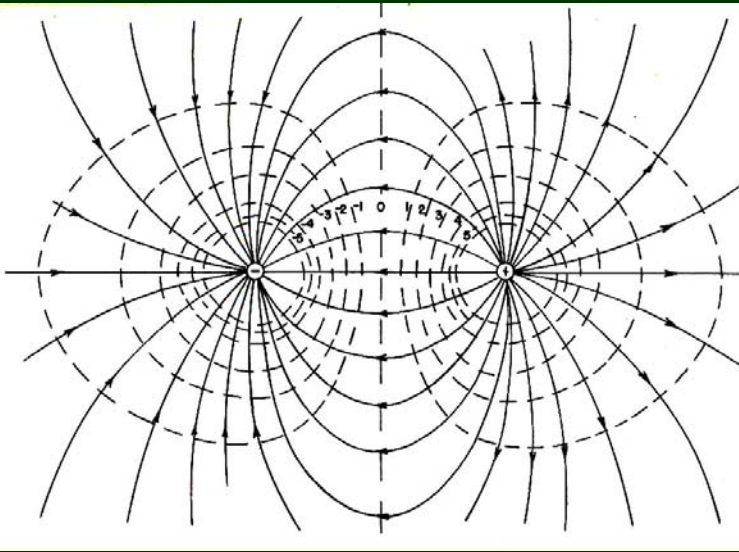

At right is the potential generated by a pair of opposite charges. At left the equipotential contours for this potential are shown as dashed lines, and the electric field lines are shown as continuous lines, flowing from high to low potential.

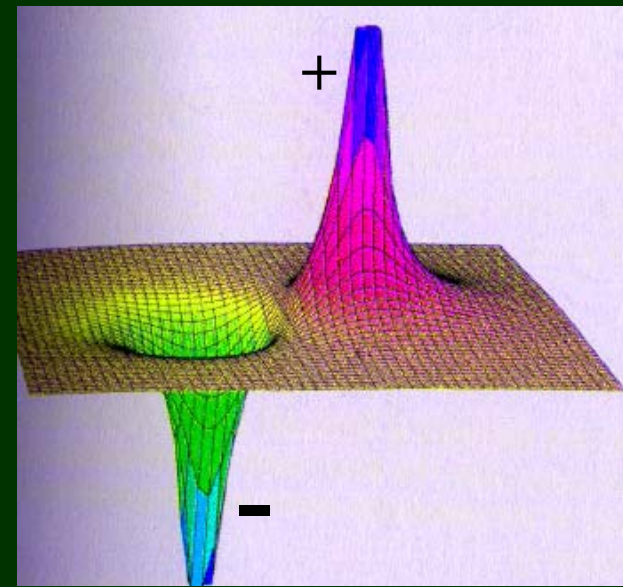

ELECTROSTATIC FIELDS III

In an electric conductor like a metal, electrons will flow until the system is everywhere at the same electrostatic potential (if not, there would still be forces on them causing them to flow!). This all electric field lines from charges on a conductor must come out perpendicular to the surface. A sharp point has a very strong electric field near its surface, coming from the charges on the surface (used, eg., in lightning conductors).

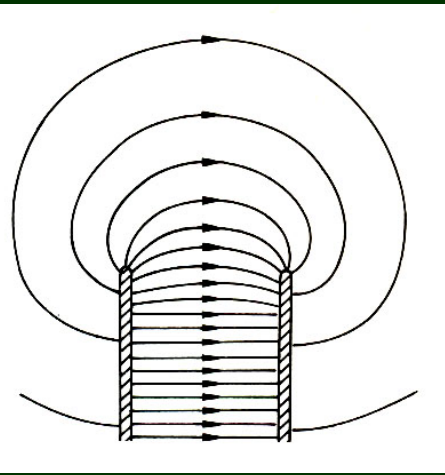
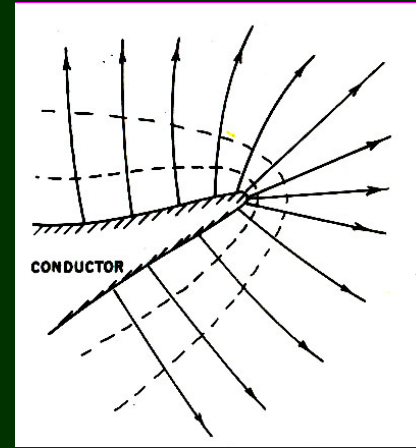

Between 2 long flat plates one gets almost parallel electric field lines, as in a capacitor (at left). Note that at the end of the capacitor field leaks out. Capacitors store + charges on one plate, and - charges on the other; and store the electric field between the 2 of them, with an associated electric field energy.

Finally, notice the field configuration when we put a charge near a conducting plate. The field lines again come in perpendicular to the surface, creating one half of what looks like a dipolar field pattern, with a fake “image charge” on the other side of the surface.

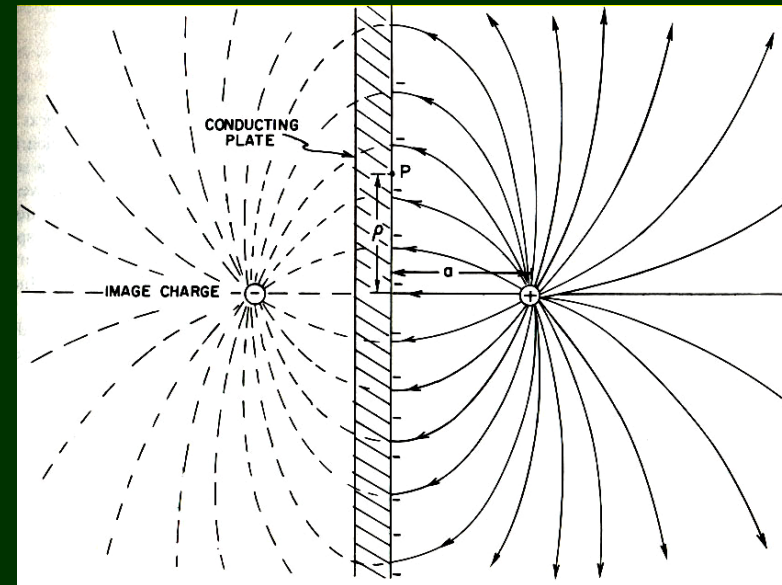

MAGNETIC FIELDS generated by ELECTRIC CURRENTS



One secret of magnetic fields is revealed when we use magnetic probes, like tiny magnetized iron filings, to show the field pattern around current-carrying wires.

The magnetized filings will lower their energy by aligning their fields to be parallel to the field generated by the current. We see that the current generates a field which “CIRCULATES” around the current, just like fluid circulating around a vortex. A current loop or ring generates a “vortex ring” pattern of field. If we add a lot of rings in parallel (by making a long coil, called a “solenoid”), we get a strong field down the inside of the solenoid, which then spreads out on emerging, eventually curling round to return.

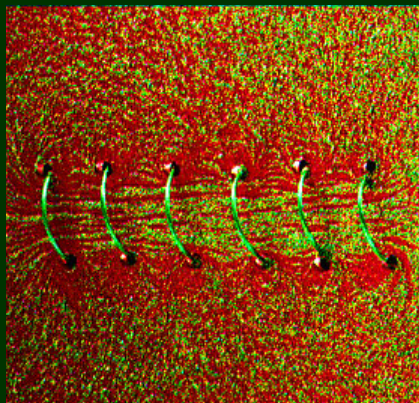

Notice there are no magnetic poles (despite searches they have never been found). Magnetic fields in Nature are generated by current loops.

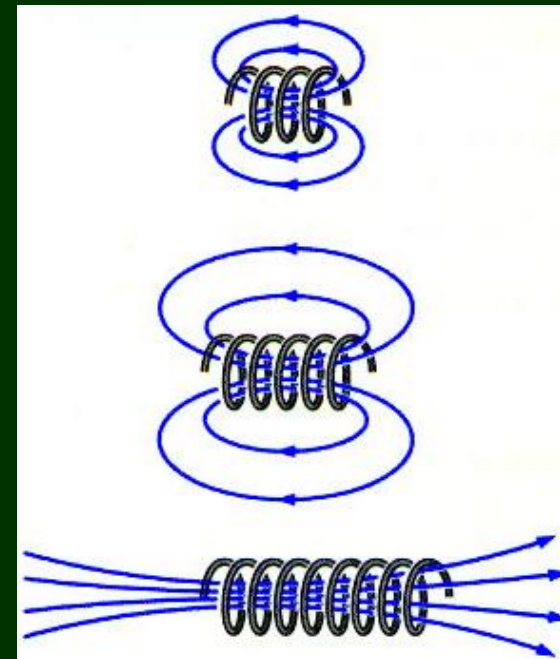

MAGNETOSTATICS

If magnetic fields are caused by electric currents, then how do permanent magnets create fields, and why do they respond to them the way they do?

At right we see the magnetic field pattern due to a long bar magnet. At first glance it looks as though we have magnetic monopoles at the 2 ends of the magnet, but a closer look shows that the field pattern is like that of a solenoid. If we break the magnet in 2 pieces, we just get a lot of little magnets, each acting like a solenoid. Now in reality magnetism comes from the tiny fields from each atom- and each of these behaves like a tiny current loop (something we shall understand when we come to quantum mechanics). If these all line up to produce parallel fields, the result is a magnet. Heating a magnet causes the atomic magnets to lose their alignment, and point in all directions- the fields all then cancel each other and the magnet loses its magnetism.

The earth generates a magnetic field- it comes from Iron and weak electrical currents in the core- both roughly aligned with the rotational axis.

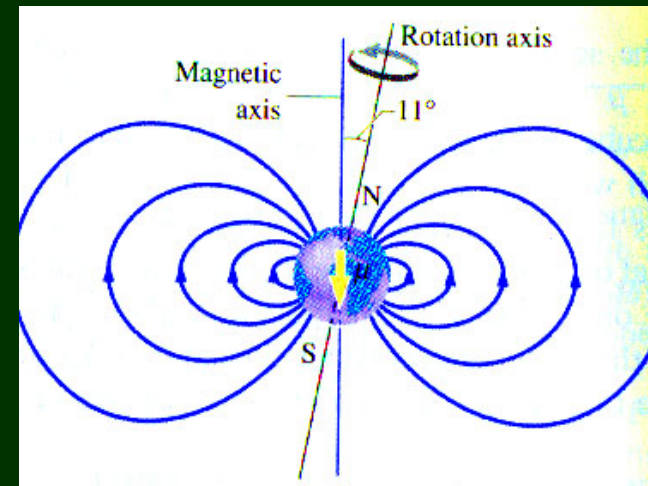
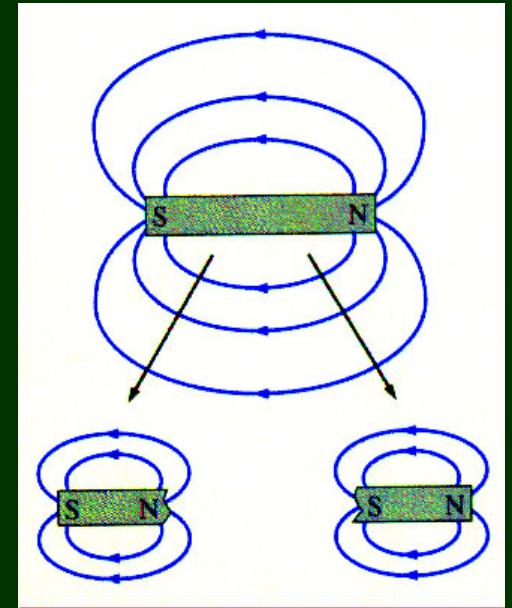
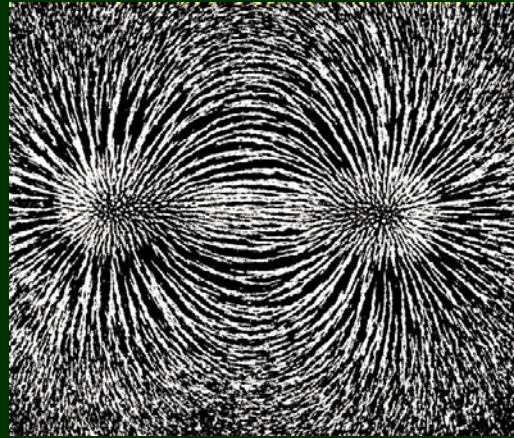

The EM FIELD: Experiments on Magnetic Fields I

It is useful to see how we can investigate the relationship between electric and magnetic fields and forces using simple experiments. Here one such set-up is shown. In the top experiment a wire carrying current generates a field which interacts with the bar magnet, and a force is exerted on the wire, perpendicular to both current and to the field generated by the bar magnet... in the lower expt. we verify that this is a bona fide force, by showing that there is an equal & opposite force generated on the bar magnet coming from the field generated by the wire current. Thus whatever is causing these forces, they are genuine forces in the sense described by Newton.

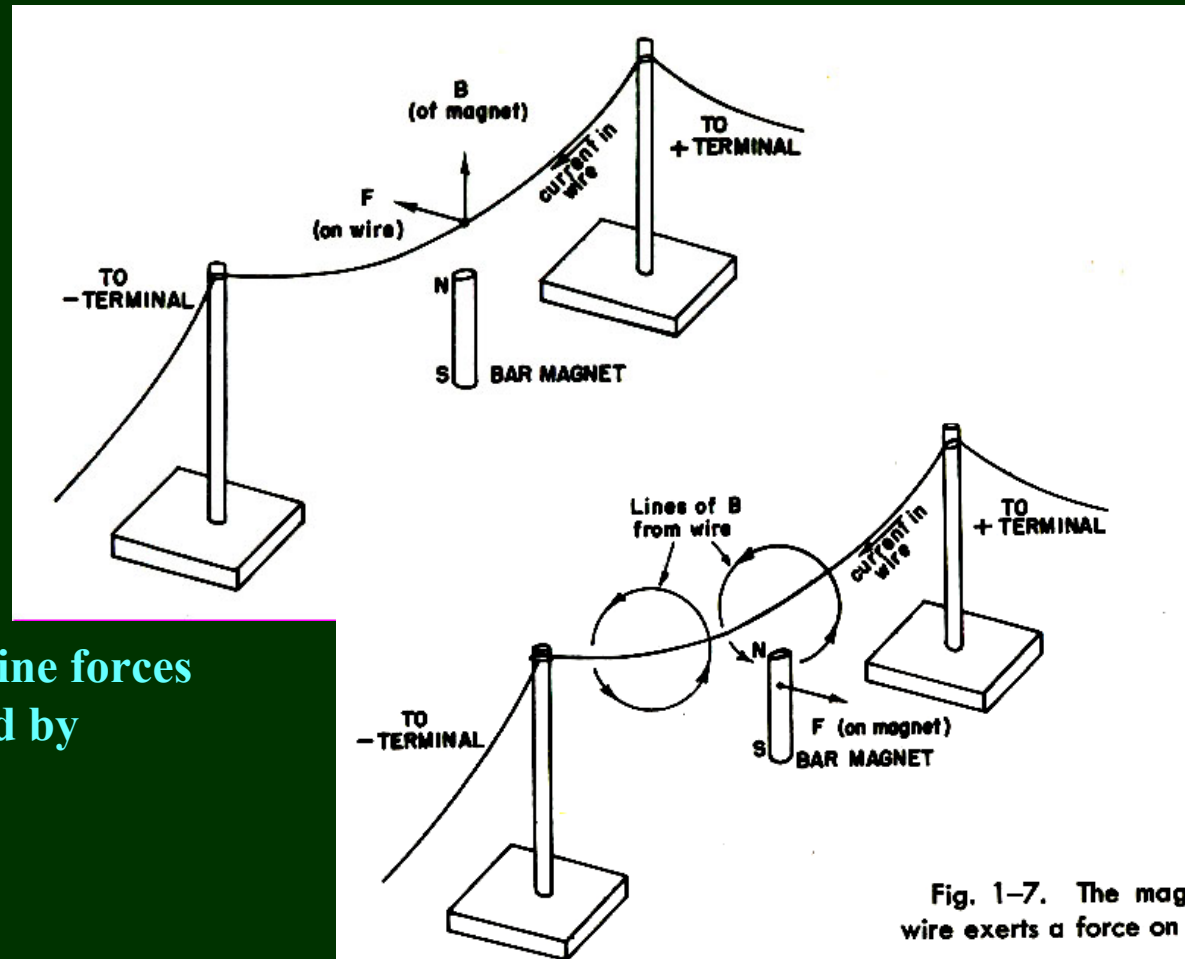

Fig. 1-7. The magnetic field of the wire exerts a force on the magnet.

The EM FIELD: Experiments on Magnetic Fields II

One may continue in this vein by looking at the interaction between 2 current-carrying wires. In the top picture we see how this works for 2 parallel currents- they actually attract each other. If we now replace the bar magnet from the last page with a solenoid-shaped wire carrying current, we find that it behaves just like the bar magnet.

In this way we establish that

(i) Electrical currents (ie, motion of electric charges) is what generates magnetic fields.

(ii) these fields in their turn act on electric currents. In this way 2 currents can interact over the space between them.

(iii) A permanent magnet behaves as though it were itself a set of aligned currents- actually, like a set of current loops.

(iv) the EM field hypothesis enables us to explain the existence of the bona fide forces which act on both charges and currents.

There is more.....

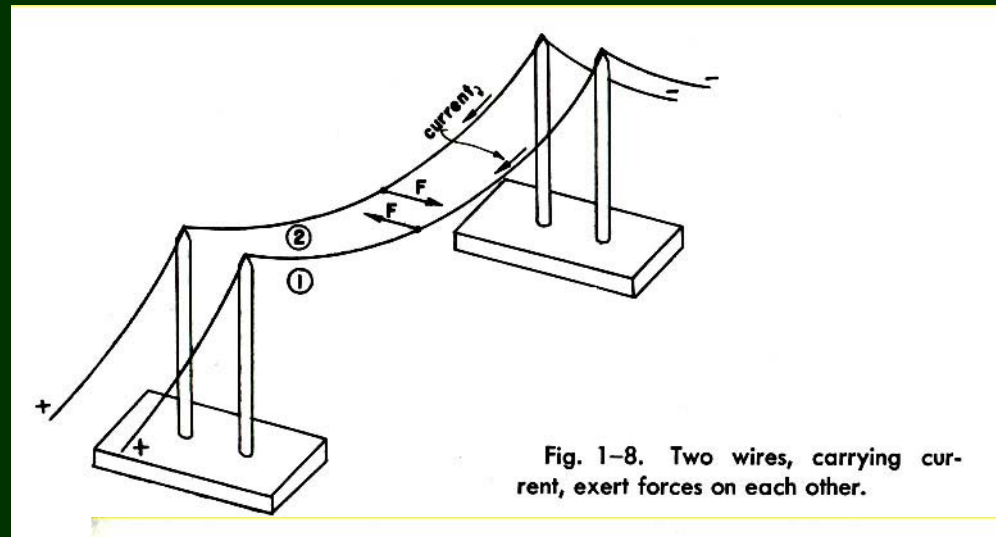

Fig. 1-8. Two wires, carrying current, exert forces on each other.

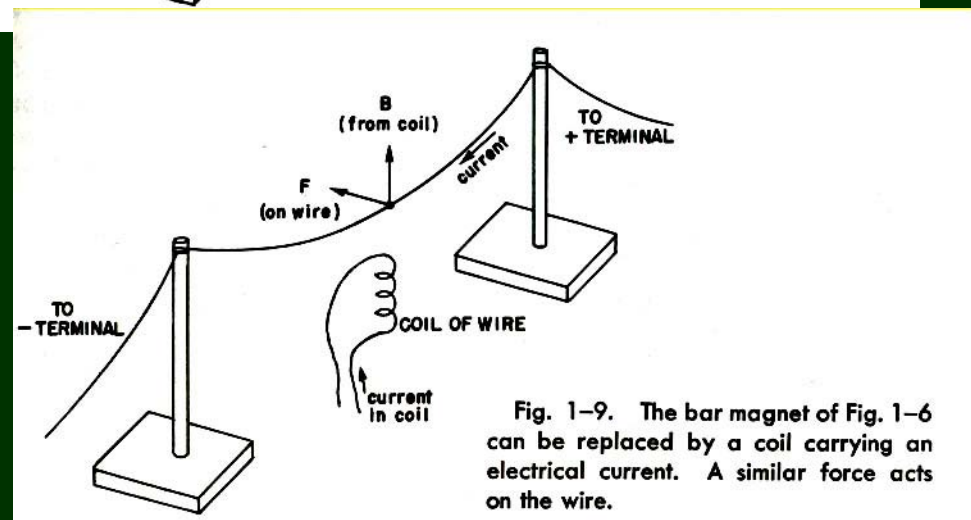
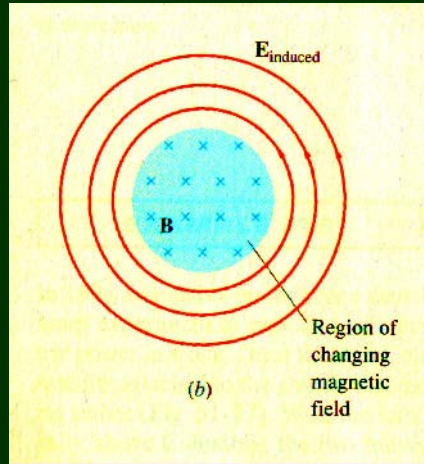
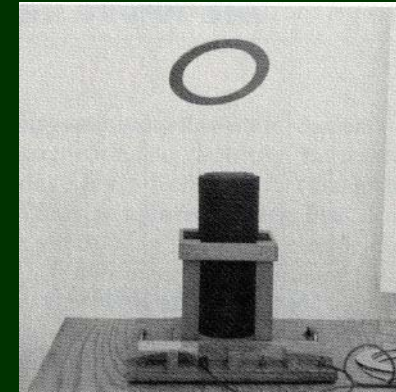
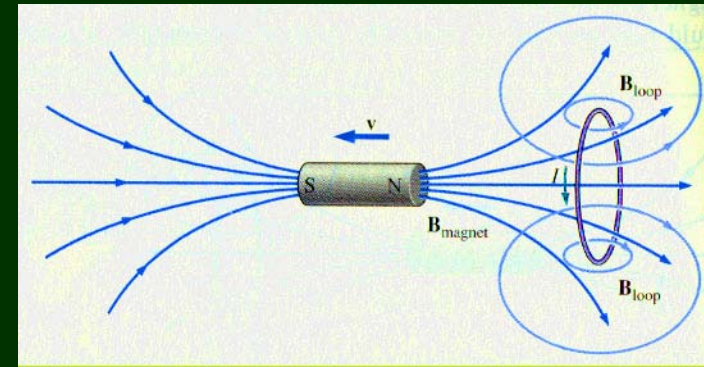

Fig. 1-9. The bar magnet of Fig. 1-6 can be replaced by a coil carrying an electrical current. A similar force acts on the wire.

ELECTROMAGNETIC INDUCTION



Suppose we now **CHANGE** a magnetic field in time...there are many ways to do this, shown in the various figures. We can change the total field through a current loop by moving the loop in the field (top right & bottom left), or by changing the current through the solenoid



Electric field around which is generating the field (see photo- the changing B-field loop in this field is then projected into the air). We find that the changing total “amount of field”, or **MAGNETIC FLUX**, through the loop, causes an electric field (see above) which drives current around the loop- notice that this can be used to provide power (below right, where turning the loop in the field changes the flux through the loop) .

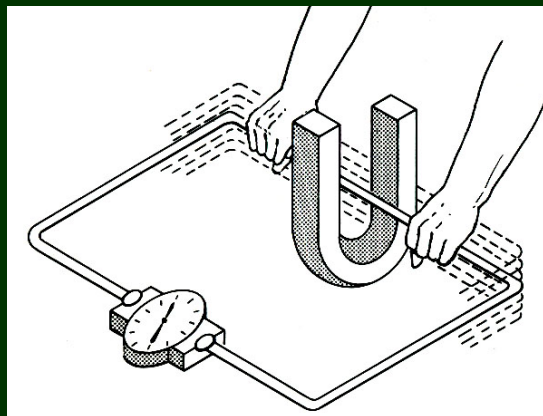

To summarize- changing the magnetic field creates an electric field. Likewise we saw that changing an electric field (eg., by moving charges) causes a magnetic field.

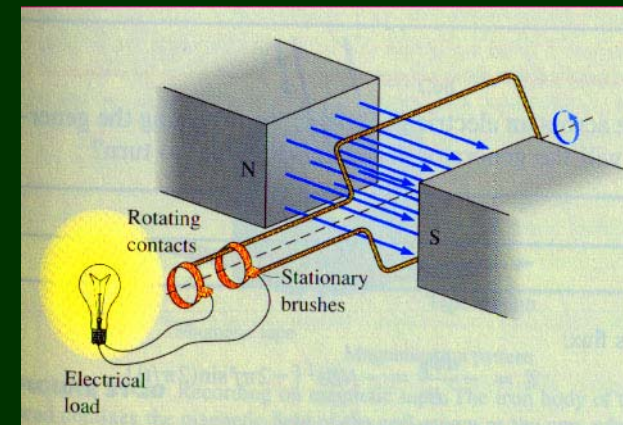

CRUCIAL EXPERIMENTS

Many physicists of the 19th century contributed to the understanding of EM phenomena. This involved the invention of new kinds of apparatus for storing charge, generating currents, and measuring electric and magnetic fields- at the time unknown concepts.

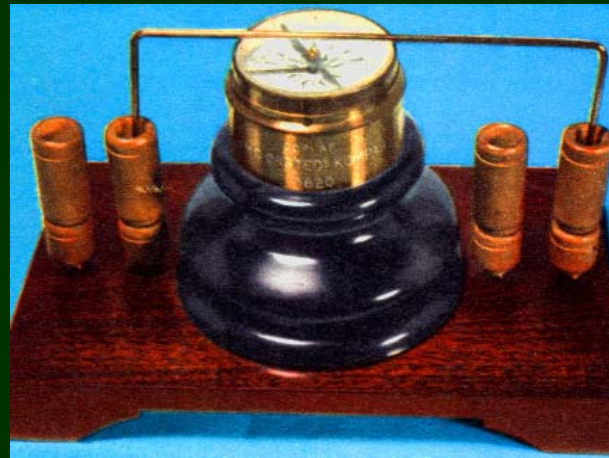

Apparatus of Oersted



H.C. Oersted (1777-1851)

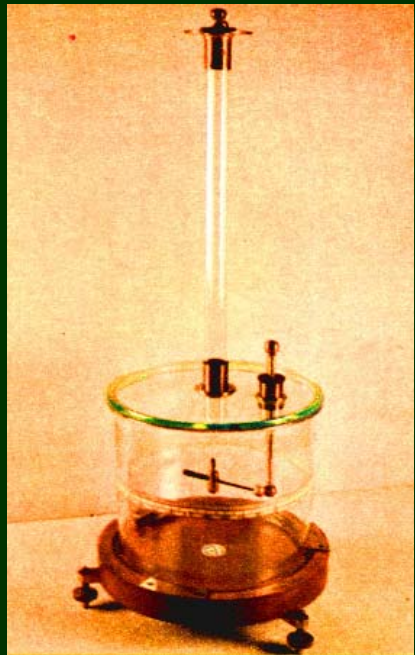

A. Coulomb
(1736-1806)

Some examples are shown- the apparatus of Oersted to measure the direction of fields near a current-carrying wire, and Coulomb's device in which charge is stored on 2 light gold leaves whose deflection from each other is proportional to the stored charge. These were early experiments- things became more sophisticated later on. Note that a separation between theory

and experiments was hardly relevant here- the investigations involved both, in a kind of detective story- although the work in countries like France was done by physicists with



A.M. Ampere
(1775-1836)

Coulomb's electrostatic apparatus

considerable mathematical training (unlike Faraday in London, who lacked even a high school education!).

The Great Synthesis → EM FIELD

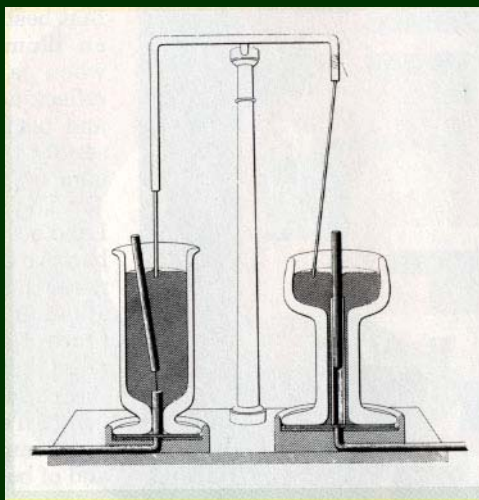

Faraday, with his many experiments and his concept of electric and magnetic “lines of force”, was able to put all the experimental work into a coherent whole. The figures show his apparatus for mapping B-fields (left) the results for current wires (above),

and the induction of current in one loop by a changing current in another (see right).

Thus was the way prepared for the great theoretical synthesis of Maxwell, who postulated a single entity, the Electromagnetic field, with sub-components **B** (magnetic field) and **E** (electric field) . A modern writing of Maxwell’s theory appears in

the form of a set of equations which can only be understood in the language of vector calculus- or an even more compact equation in terms of tensor calculus.

Like any real theory, Maxwell’s had predictive power- it implied the existence of phenomena and of relations between them, which were previously unexpected and surprising. The most obvious of these was EM waves.... (next slide)

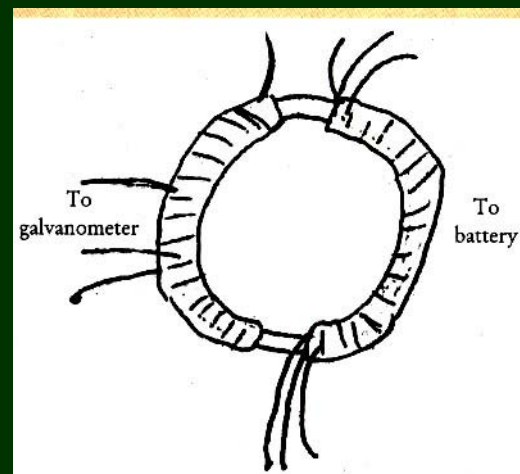
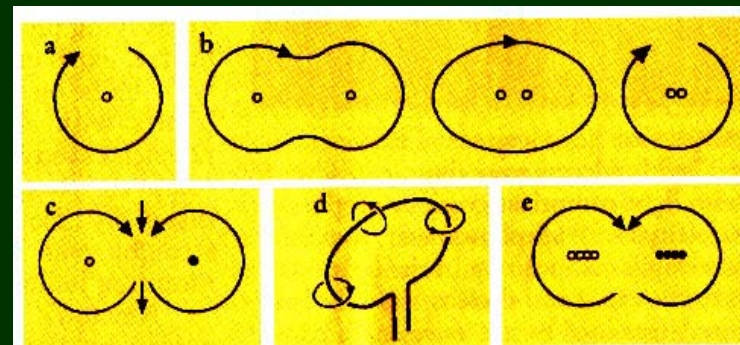

$$\nabla \times \mathbf{E} = - \frac{\partial \mathbf{B}}{\partial t}$$

$$\nabla \cdot \mathbf{D} = \rho$$

$$\nabla \times \mathbf{H} = \mathbf{J} + \frac{\partial \mathbf{D}}{\partial t}$$

$$\nabla \cdot \mathbf{B} = 0$$

The EM FIELD: Electric & Magnetic Fields together

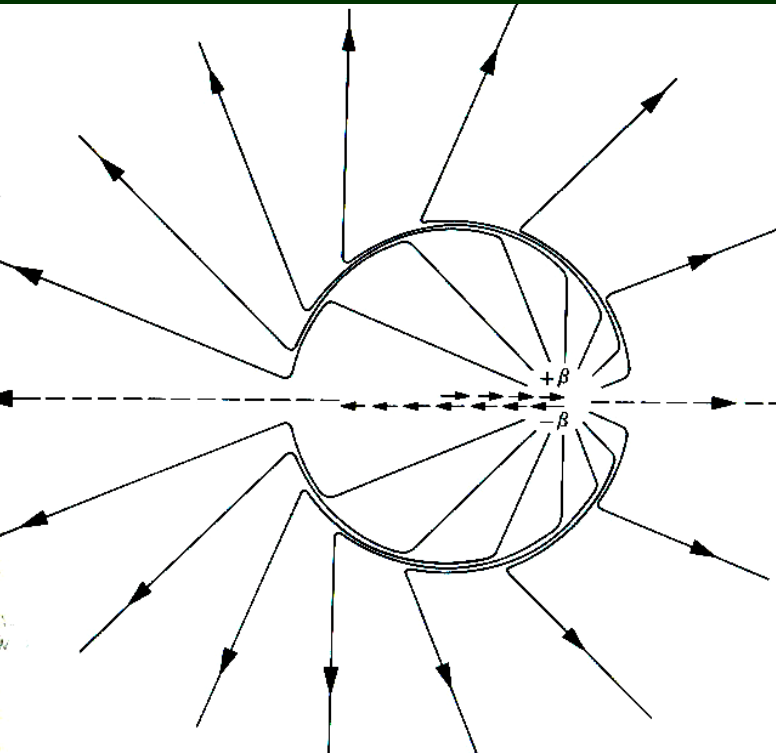

Suppose we now take a single charge and move it. The first thing we can ask is how the electric field will vary. At left we see what happens if a charge is suddenly moved to the right- the field readjusts to the new position of the charge, but we assume that the change in the field can only propagate at a finite speed. If the velocity of the moving charge approaches this propagation velocity, then we get something resembling a shock wave. An observer outside this will see the field as if the charge had not yet moved.

If we now cause the charge to oscillate (see right) a wave-like distortion of electric field is produced, which also moves out at some velocity- called here c .

We have already seen that a time-varying electric field causes a magnetic field- which itself is time-varying here. One sees that the net result will be a wave motion in which both fields are oscillating, and moving at velocity c .

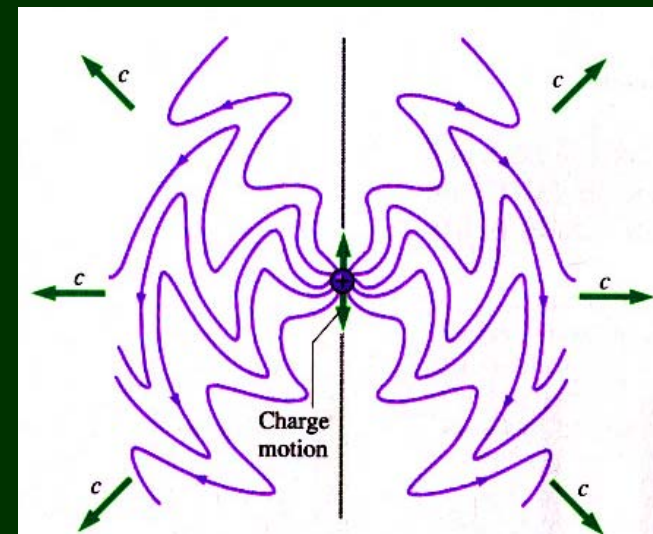

ELECTROMAGNETIC WAVES

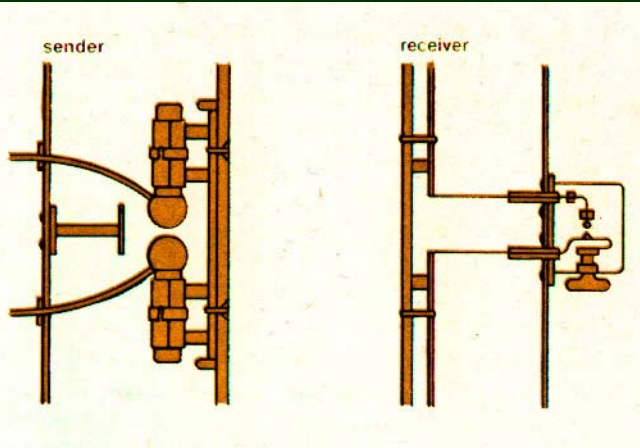

The demonstration of the fact that EM waves existed came from H. Hertz in 1885; a spark in one circuit was picked up in another one some distance away. As predicted by Maxwell, the velocity was that of light (already measured

accurately by many, beginning with Roemer in 1660).

Maxwell's theory predicted that light was a **TRANSVERSE** wave- the oscillations of **B** & **E** were in a direction transverse to the direction of propagation of the wave (and the 2 fields were exactly out of phase with each other). At the time it was assumed these were waves through a medium (called the 'ether').

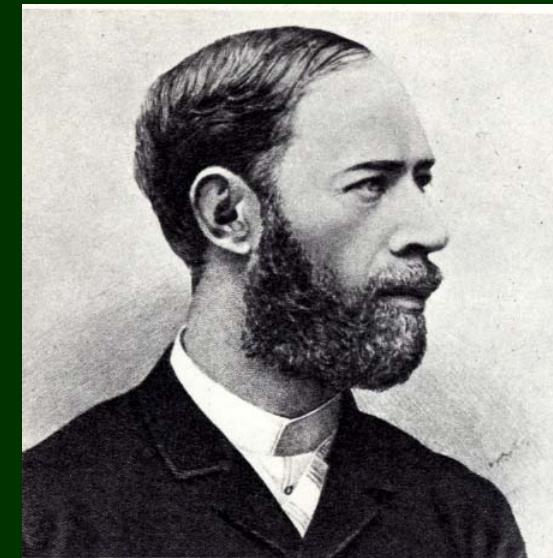

H. Hertz (1857-94)

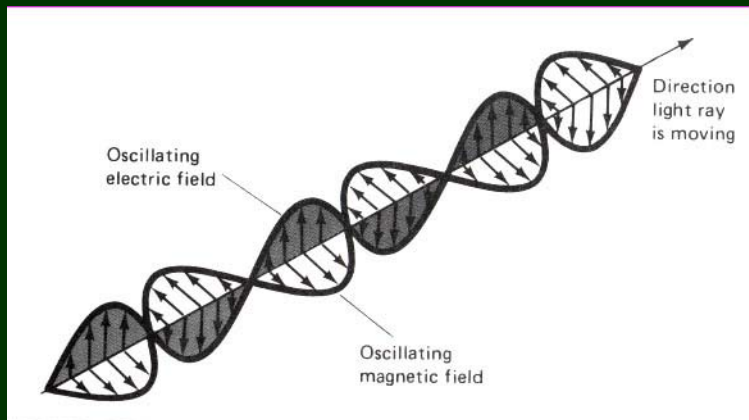

The transverse nature of the waves can be seen in polarised light. Some materials only transmit light if the **E**-field oscillates in a certain direction. 2 perpendicular such glasses stop all light



The EM SPECTRUM

The decades that followed Maxwell's theory led to a slow extension of the frequency/wavelength range studied & used—indeed, the rise of technology in the 20th century is based on this. Much of modern technology involves signal transmission and reception in some part of the EM spectrum. Most of our understanding of the universe is based on study of EM radiation, from gamma rays to the microwave background.

